



GFS FORMWORK RENTAL L.L.C



dreamstime

sales@gfsformwork.com

ABOUT US

GFS FORMWORK RENTAL LLC has built a strong reputation as a trusted partner in the construction industry, blending deep engineering expertise with modern technologies to deliver advanced concrete formwork systems. Our solutions meet the highest standards of quality, safety, and efficiency.

Backed by a dedicated team of designers, engineers, and project managers, we have successfully delivered many of projects across the UAE. Our continued growth reflects our commitment to supporting the region's evolving construction landscape with innovative and reliable solutions.

Smart, Cost-Effective, and Efficient Formwork Solutions

What sets GFS FORMWORK RENTAL LLC apart is our focus on smart systems that enable faster execution and significant cost reductions without compromising on quality. Our formwork is engineered for durability and reusability across multiple construction cycles—translating into long-term savings and streamlined project timelines.



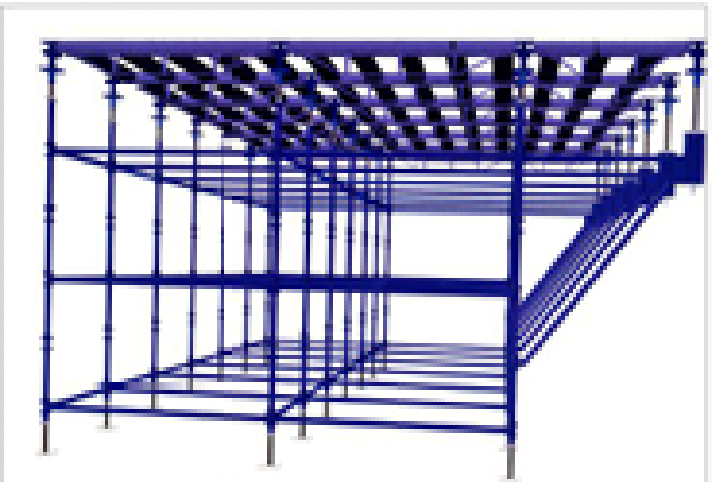
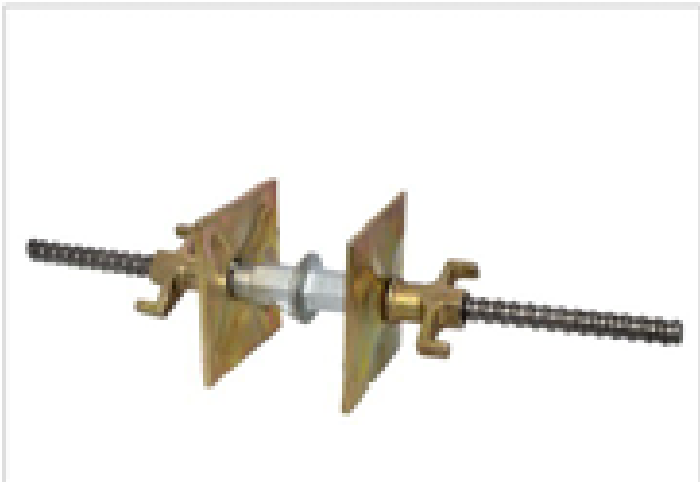
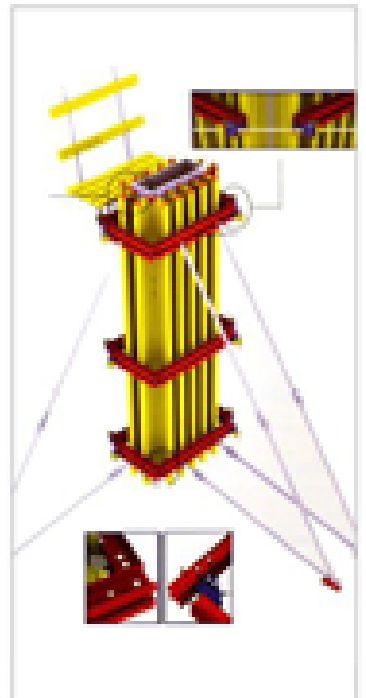
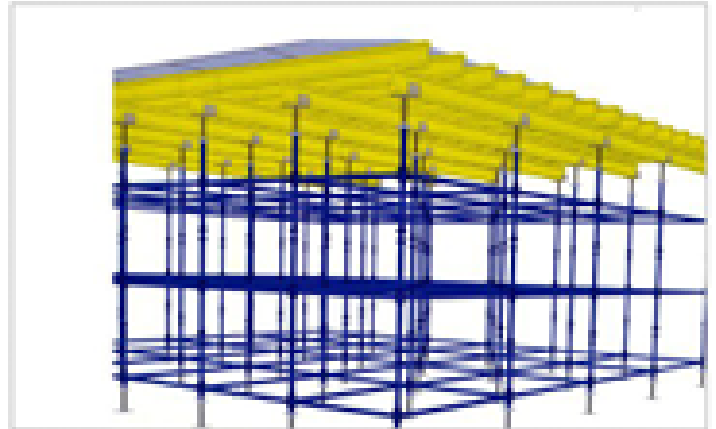
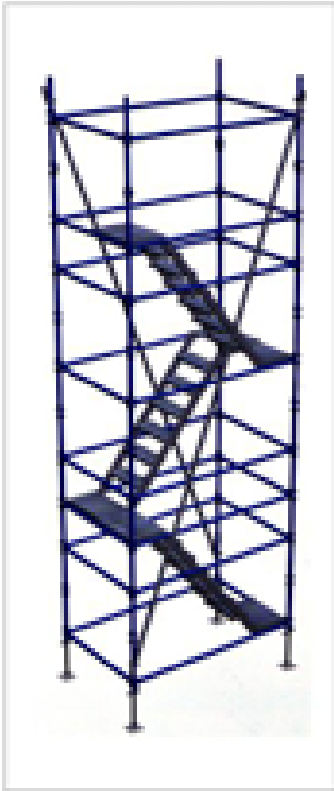



* #

FIX COUPLER FORGED 48/48

Weight 0.95 kg



* #

SWIVEL COUPLER FORGED 48/48

Weight 1.05 kg



* #

FIX COUPLER FORGED 48/60

Weight 1.15 kg



* #

SWIVEL COUPLER FORGED 48/60

Weight 1.25 kg



* #

FIX COUPLER SHEET 48/48

Weight 0.650 kg



* #

SWIVEL COUPLER SHEET 48/48

Weight 0.750 kg



* #

FIX COUPLER SHEET 48/60

Weight 0.720 kg



* #

SWIVEL COUPLER SHEET 48/60

Weight 0.770 kg



* #

PUTLOG COUPLER EURO

Weight 0.610 kg



* #

BRC COUPLER GULF

Weight 0.610 kg



* #

PUTLOG COUPLER EURO

Weight 0.610 kg



* #

PUTLOG GULF

Weight 0.610 kg

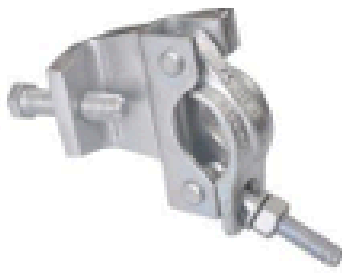

* #

GIRDER CLAMP

Weight 1.45 kg



* #

ROOFING COUPLER

Weight 1.30 kg



* #

FENCING COUPLER

Weight 0.34 kg



* #

SLEEVE COUPLER GULF

Weight 1.00 kg



* #

SLEEVE COUPLER EURO

Weight 1.00 kg

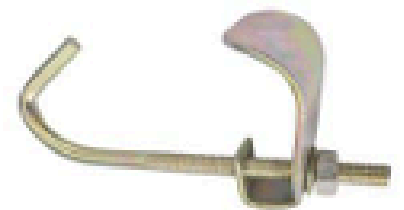

* #

LADDER CLAMP

Weight 0.48 kg



* #

FLANGE CLAMP

Weight 0.85 kg

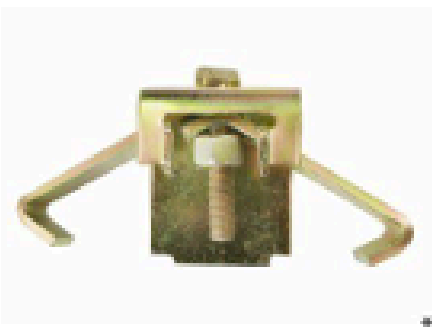

* #

H20 CLAMP

Weight 0.60 kg

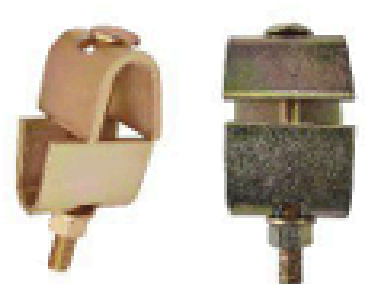

* #

UNIVERSAL CLAMP

Weight 0.48 kg



* #

BAND PLATE

Weight 0.45 kg



* #

T BOARD COUPLER

Weight 0.34 kg

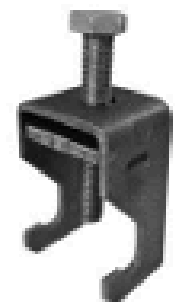

* #

C CLAMP

Weight 0.65 kg

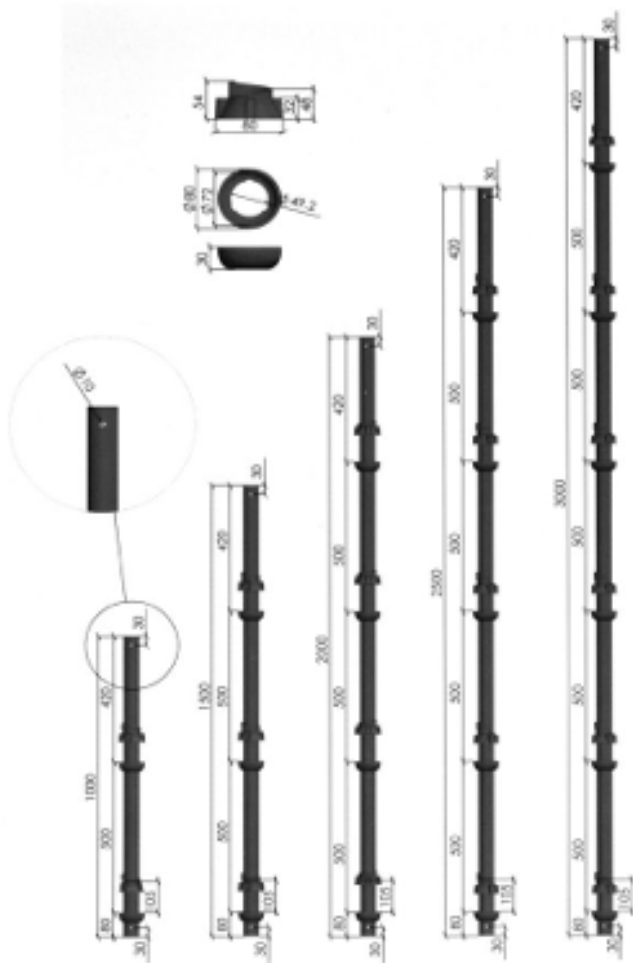

CANTILIVER FRAME * #
Weight 15.8 kg



SAFETY HANDRAIL * #
Weight 3.9 kg



CUPLOCK STANDARD
Thickness 3mm/3.2mm



CUPLOCK LEDGER * #
Thickness 3mm/3.2mm



INTERMEDIATE TRANSOME * #
Thickness 3mm/3.2mm



DROP HEAD * #
Weight 4.8 kg



S.NO	SIZE	WEIGHT / PC (3MM)	WEIGHT/ PC (3.2 MM)	RATE
1	CUPLOCK STANDARD 1 MTR (3.2 MM)	4.53 KG	4.7 KG	
2	CUPLOCK STANDARD 1.50 MTR (3.2 MM)	6.75 KG	7.1 KG	
3	CUPLOCK STANDARD 2 MTR (3.2 MM)	9.00 KG	9.4 KG	
4	CUPLOCK STANDARD 2.5 MTR (3.2 MM)	11.25 KG	11.8 KG	
5	CUPLOCK STANDRAD 3 MTR (3.2 MM)	13.50 KG	14.1 KG	

S.NO	SIZE	WEIGHT / PC (3MM)	WEIGHT/ PC (3.2 MM)	RATE
1	CUPLOCK LEDDER 1 MTR (3.2 MM)	3.47 KG	3.6 KG	
2	CUPLOCK LEDDER 1.2 MTR (3.2 MM)	4.13 KG	4.4 KG	
3	CUPLOCK LEDDER 1.3 MTR (3.2 MM)	4.46 KG	4.7 KG	
4	CUPLOCK LEDDER 1.5 MTR (3.2 MM)	5.12 KG	5.4 KG	
5	CUPLOCK LEDDER 1.6 MTR (3.2 MM)	5.45 KG	5.75	
6	CUPLOCK LEDDER 1.8 MTR (3.2 MM)	6.11 KG	6.45	
7	CUPLOCK LEDDER 2.5 MTR (3.2 MM)	8.42 KG	8.9 KG	

S.NO	SIZE	WEIGHT / PC (3MM)	WEIGHT/ PC (3.2 MM)	RATE
1	CUPLOCK TRANSOME 0.9 MTR (3.2 MM)	4.56 KG	4.7 KG	
2	CUPLOCK TRANSOME 1 MTR (3.2 MM)	4.89 KG	5.0 KG	
3	CUPLOCK TRANSOME 1.2 MTR (3.2 MM)	5.55 KG	5.8 KG	
4	CUPLOCK TRANSOME 1.30 MTR (3.2 MM)	5.88 KG	6.2 KG	
5	CUPLOCK TRANSOME 1.50 MTR (3.2 MM)	6.54 KG	6.8 KG	
6	CUPLOCK TRANSOME 1.60 MTR (3.2 MM)	6.87 KG	7.2 KG	
7	CUPLOCK TRANSOME 1.80 MTR (3.2 MM)	7.53 KG	7.9 KG	
8	CUPLOCK TRANSOME 2.50 MTR (3.2 MM)	9.84 KG	10.4 KG	

S.NO	PRODUCT	WEIGHT
1	Decking Beam 1200mm	14KG
2	Decking Beam 1800mm	21KG
3	Decking Beam 2500mm	29KG

S.NO	PRODUCT	WEIGHT
1	Infill Beam 1000mm	4.95KG
2	Infill Beam 1250mm	5.95KG
3	Infill Beam 1600mm	7.90KG
4	Infill Beam 1800mm	8.75KG

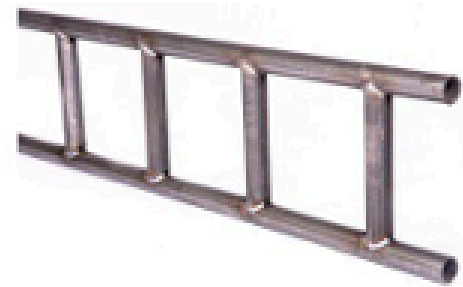
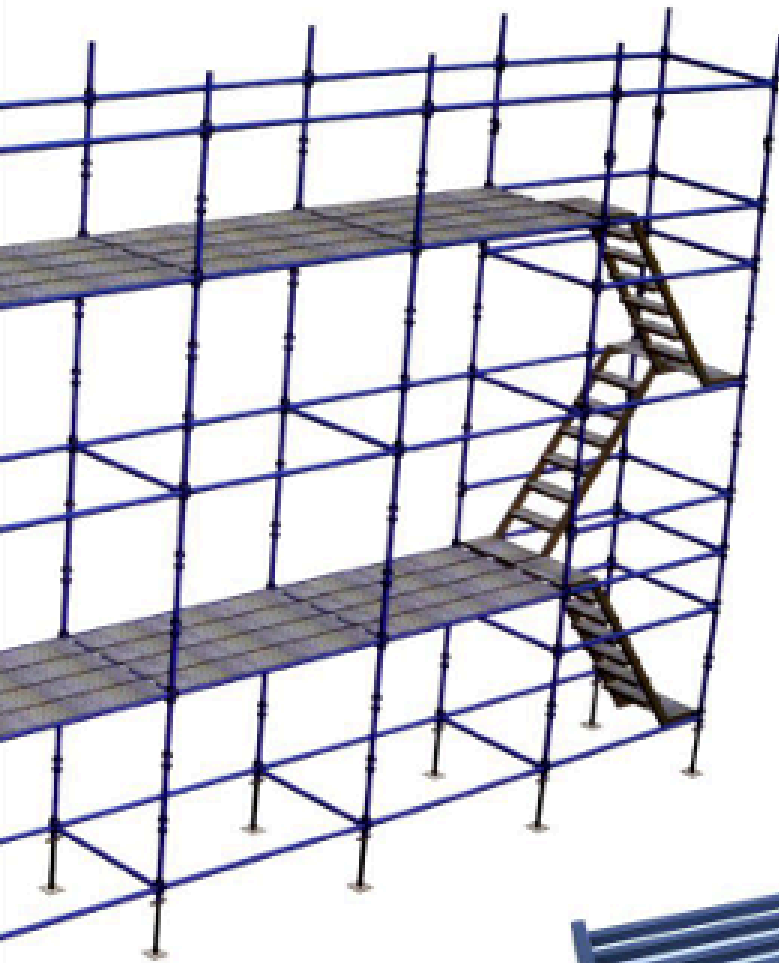

BEAM LADDERS WITH SADDLE CUT

ALL WEIGHTS FOR 350 MM WIDTH AND 330 MM STEP DISTANCE

S.NO	PRODUCT	WEIGHT
1	BEAM LADDER 2 MTR X 3.2 MM	20.75 KG
2	BEAM LADDER 3 MTR X 3.2 MM	31.1 KG
3	BEAM LADDER 4 MTR X 3.2 MM	41.5 KG
4	BEAM LADDER 5 MTR X 3.2 MM	51.8 KG
5	BEAM LADDER 6 MTR X 3.2 MM	62.2 KG

PLEASE NOTE :
PIPE THICKNESS AVAILABLE 3 MM - 4 MM



MS CHALI | WALKAWAY PLATFORM

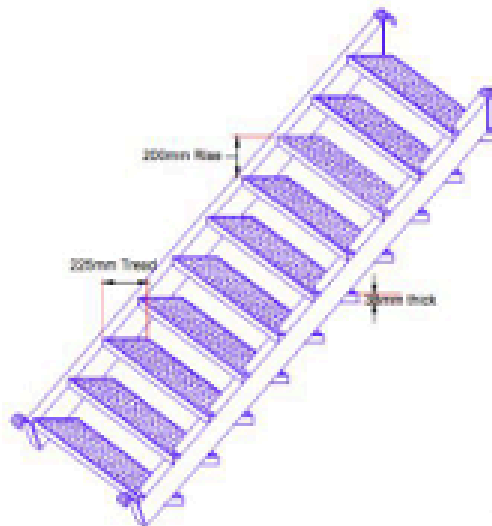

STAIR LADDER

size 1.5 mtr -- 70 kg
size 2.5 mtr -- 134 kg

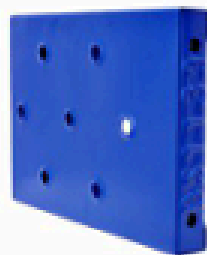

STEEL BOARDS

BOARD SIZE 225 MM X 38 X 1.5 MM WITH STIFFNER SUPPORT

S.NO	PRODUCT	WEIGHT
1	STEEL BOARD 1 MTR X 1.5 MM	3.5 KG
2	STEEL BOARD 1.5 MTR X 1.5 MM	5.25 KG
3	STEEL BOARD 2 MTR X 1.5 MM	7 KG
4	STEEL BOARD 2.5 MTR X 1.5 MM	8.75 KG
5	STEEL BOARD 3 MTR X 1.5 MM	10.5 KG

PLEASE NOTE :
BOARD THICKNESS AVAILABLE 1.5 MM - 4 MM

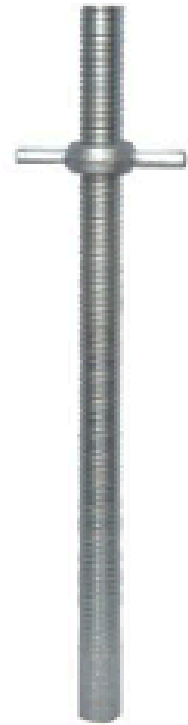
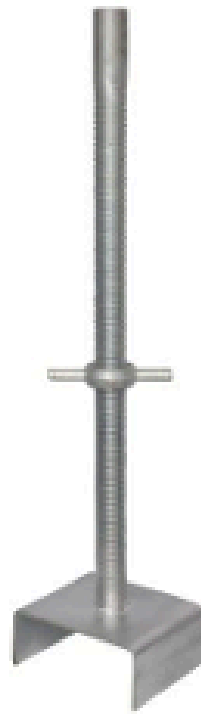
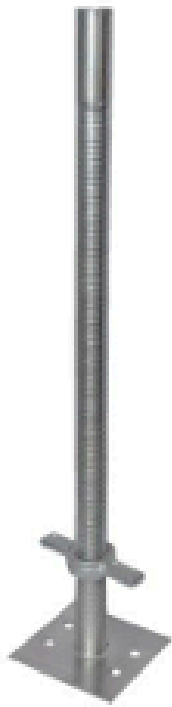

BASE JACK HOLLOW
Plate 150×150×5 mm

U HEAD JACK HOLLOW
U-Head 150×170×190×5mm

BASE JACK EUROPE
Lentgh 660/760 mm

UNIVERSAL JACK
Lentgh 660/760 mm



BASE JACK SOLID
Rod Thickness 28-40mm

U HEAD JACK SOLID
Rod Thickness 28-40mm

S.NO	PRODUCT	WEIGHT/PC
1	BASE JACK 660 MM	3.15 KG
2	BASE JACK 760 MM	3.6 KG
3	U HEAD JACK 660 MM	4.15 KG
4	U HEAD JACK 760 MM	4.6 KG
5	JOINT PIN 300 MM WITH NUT BOLTS	600 GM
6	JOINT PIN 250 MM WITH NUT BOLTS	520 GM
7	JOINT PIN 300 MM WITH WASHER	580 GM
8	JOINT PIN 250 MM WITH WASHER	500 GM
9	BASE PLATE 150 X 150 X 5 MM . ALL KIND OF CROSS SECTIONS AND THICKNESS AVAILABLE FOR PIPES .	

PLEASE NOTE :
 PIPE THICKNESS FOR JACKS 3.6 - 4 MM AS PER REQUIREMENT
 BASE AND U HEAD THICKNESS AND SIZE ADJUSTABLE AS PER REQUIREMENT
 PIPE THICKNESS FOR JOINT PIN 2 - 3 MM AS PER REQUIREMENT
 FINISH AVAILABLE - ELECTROGALVANISED , HOT DIP AND PAINTED
 NUTS USED JACKS IS DROP FORGED
 PACKING AVAILABLE IN STEEL AND WOODEN PALLETS

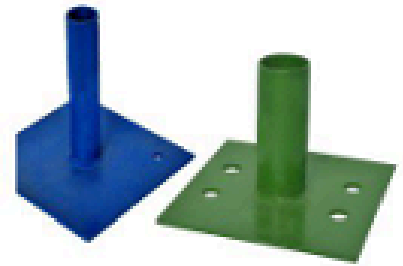
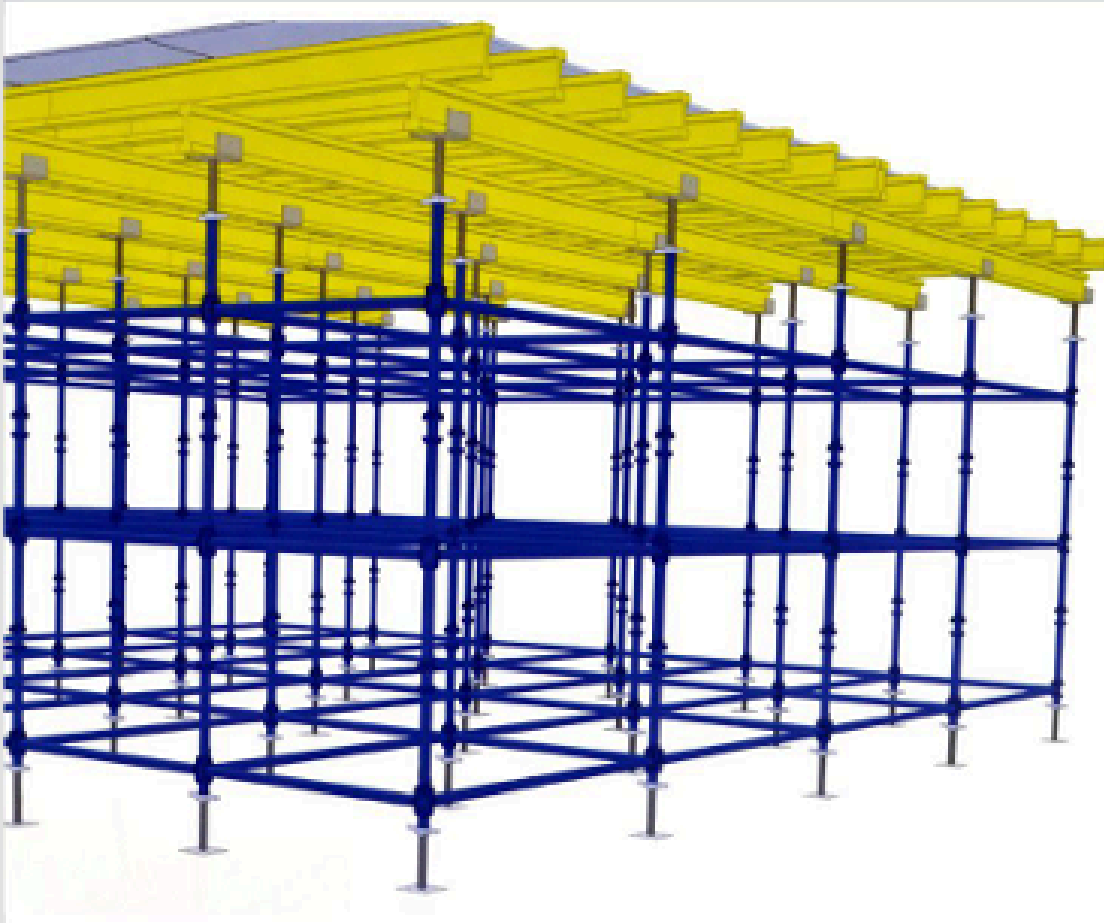

BASE PLATE
Plate 150×150×5 mm

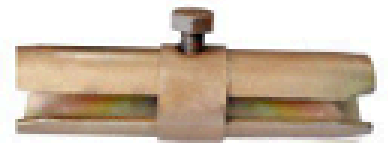

JOINT COUPLER
Weight .680 kg

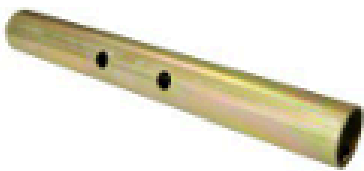

JOINT PIN
Lentgh 250/300mm



SPIGOT PIN
Lentgh 250/300 mm



SHORE PIN
Weight 0.600 kg



SPIGOT PIN DOUBLE SUPPORT
Lentgh 250/300 mm



SPIGOT PIN SQUARE
Lentgh 250/300 mm



JACKNUT CASTED/FORGED
Weight 0.41 kg



TABLE SYSTEM



TRIPOD

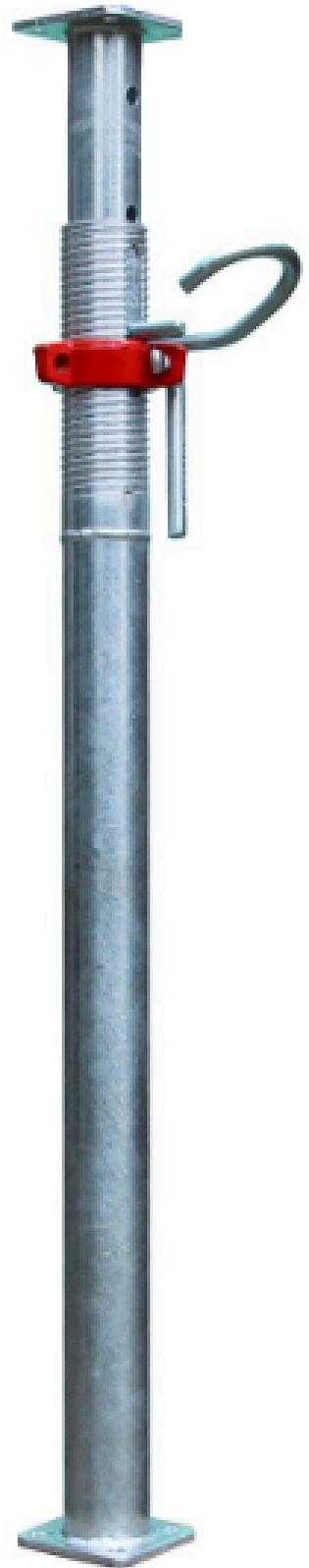

SHORING PROP



FORKHEAD HEAVY

Weight 3.8 kg



FORKHEAD MEDIUM

Weight 3.0 kg



FORKHEAD LIGHT

Weight 2.5 kg



PROP JACK

Lentgh 2mtr-4mtr
Thickness 1.8-2.5mm



76 O.D SLEEVE

Lentgh 210-300mm
Thickness 3.2-4 mm



60 O.D SLEEVE

Lentgh 210-300mm
Thickness 2.9-4.0 mm



G LOCK PIN

Thickness 10-16mm



PROP PLATE

Size 117 * 117 mm
Thickness 3.5-6 mm



ACCESSORIES

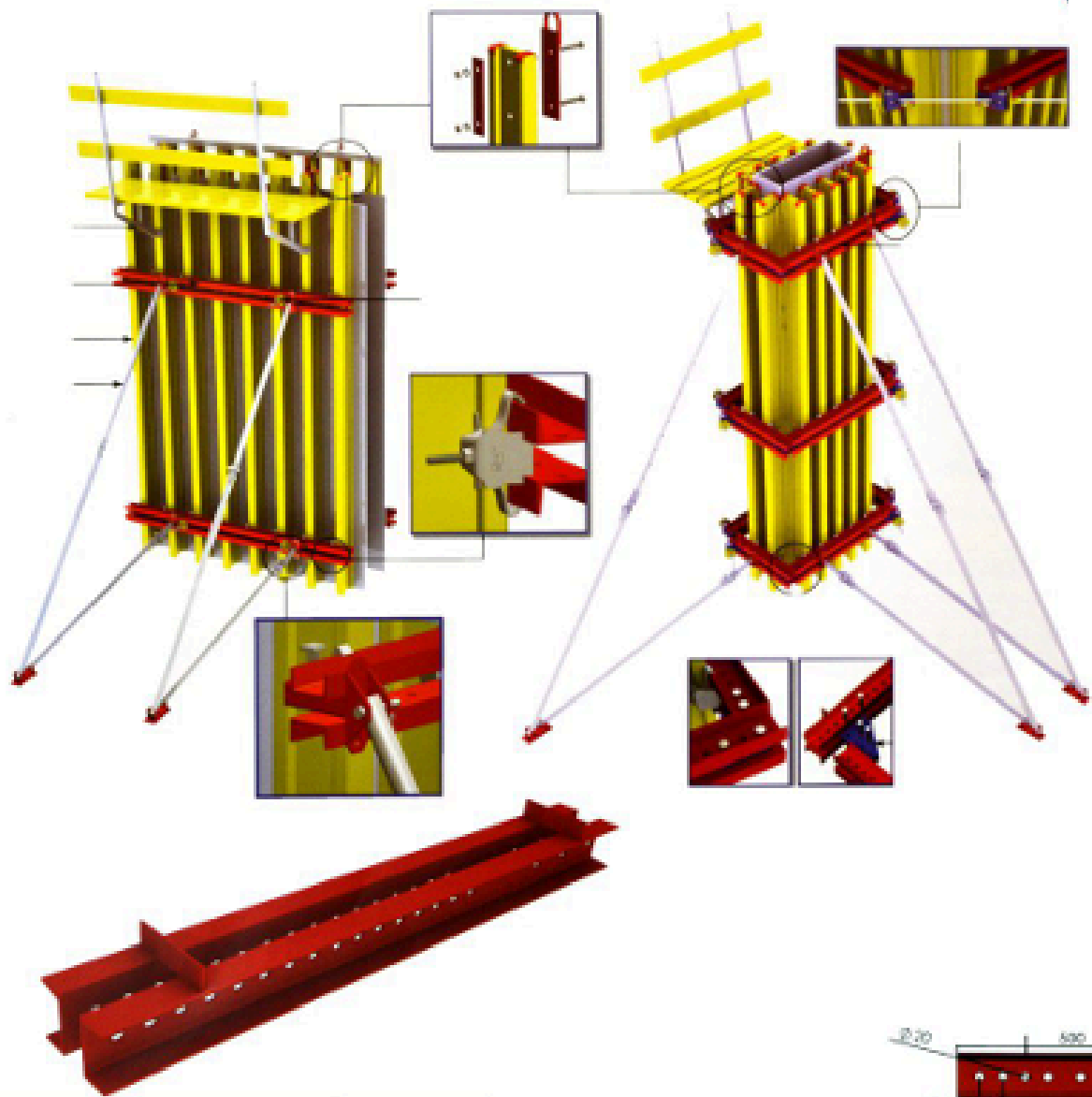

S.NO	PRODUCT	WEIGHT
1	STEEL WALLER - 0.50 MTR	11 KG
2	STEEL WALLER - 0.75 MTR	16.5 KG
3	STEEL WALLER - 1 MTR	22 KG
4	STEEL WALLER - 1.25 MTR	27.5 KG
5	STEEL WALLER - 1.50 MTR	33 KG
6	STEEL WALLER - 1.75 MTR	38.5 KG
7	STEEL WALLER - 2.0 MTR	44 KG
8	STEEL WALLER - 2.25 MTR	49.5 KG
9	STEEL WALLER - 2.40 MTR	52.8 KG

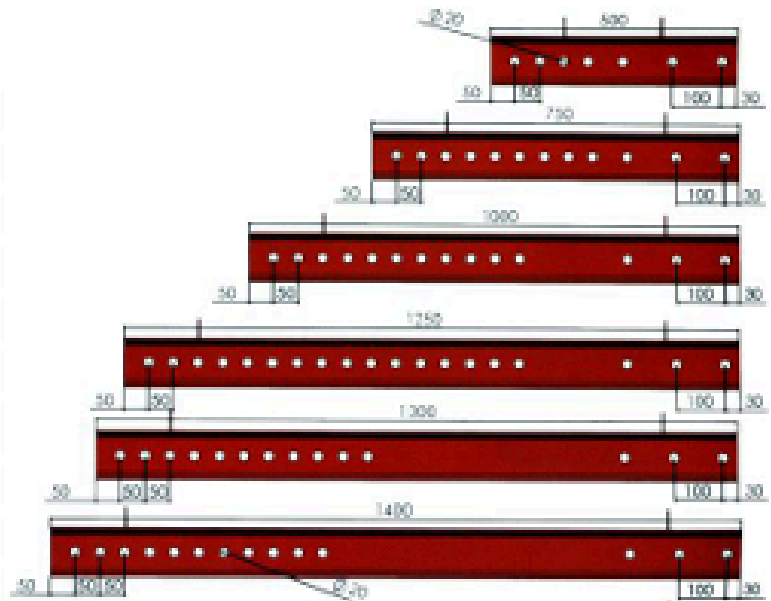

STEEL WALLERS



SUPPORT BRACKET

Weight 11 kg



ANGLE TIE

Weight 4.5 kg



BASE SUPPORT

Weight 4 kg

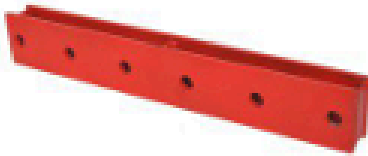

EXTENSION SPLICE

550 mm 5.7 kg
750 mm 7.8 kg



SINGLE BASE

Weight 1.49 kg

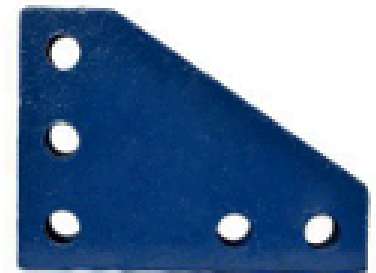

CORNER BRACKET

Weight 2.1 kg



WOODEN PLANK

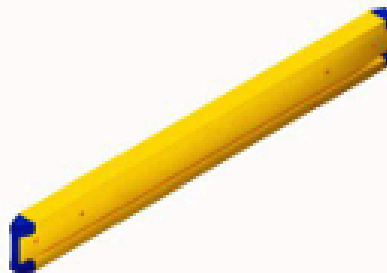

H20 BEAM



TENSION PINS

16 mm .200 kg
19 mm .350 kg
Material 8.8 grade boron steel



PUSH PULL PROP

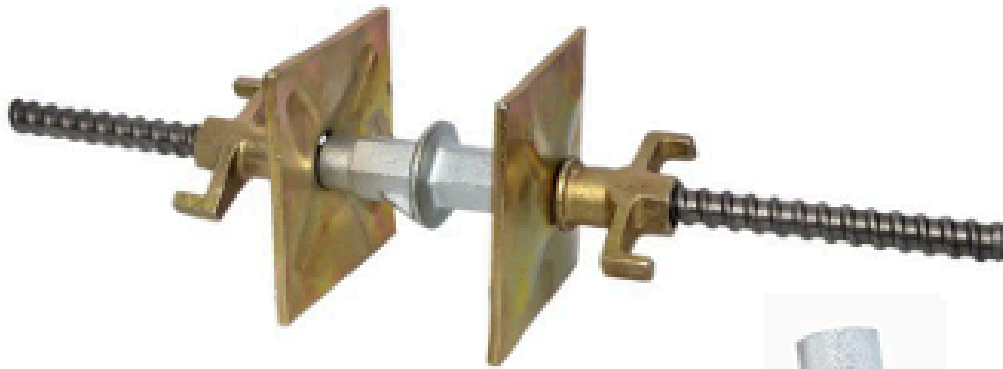

TIEROD	
size	16 mm
weight	8/.1 / 8.3 8.8 /9 kg
Finish	Self / Galvanised

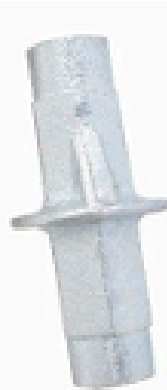

WINGNUT	
size	16 mm/20mm
material	Casted / Forged
thread	ACME/BSW

WATERSTOPPER	
size	16 mm/20mm
material	Casted / Forged
thread	ACME/BSW



WALLER PLATE	
Size	120 x 120 mm
Thickness	4 mm - 10 mm
Finish	Galvanised

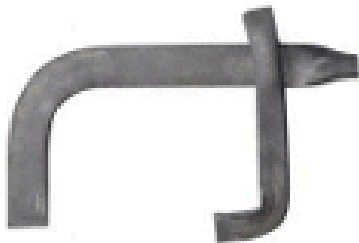

SHUTTERING CLAMP	
Width	25-40 mm
Thickness	4.5-8 mm
Size as per requirement	

HEX NUT	
size	16 mm/20mm
material	Casted / Forged
thread	ACME/BSW



COMBINATION PLATE	
size	16 mm/20mm
material	Casted / Forged
thread	ACME/BSW



RAPID CLAMP	
weight	310/400kg
Finish	Powder Coated/ Galvanised

L BOLT	
Thickness	8-14 mm
Lentgh	as per requirement
Finish	Self / Galvanised

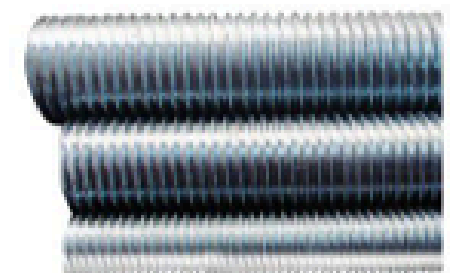

THREAD BAR	
Thickness	8-14 mm
Lentgh	as per requirement
Finish	Self / Galvanised



ANCHOR NUT HEAVY

size 90 / 100mm



ANCHOR NUT MEDIUM

size 90 / 100mm



ANCHOR NUT LIGHT

size 90 / 100mm

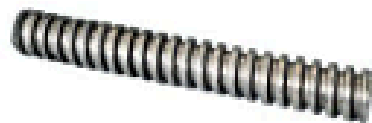

TIEROD BRITISH THREAD

size 16 / 20 mm



WINGNUT HEAVY

size 16 / 20 mm

H FRAME SYSTEM

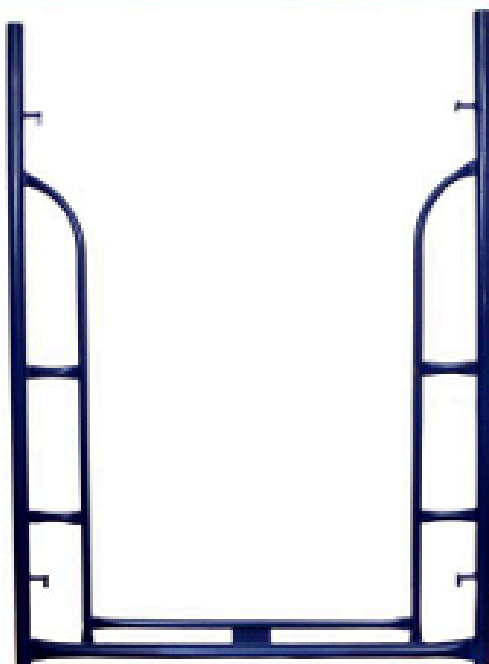

KOREAN FRAME

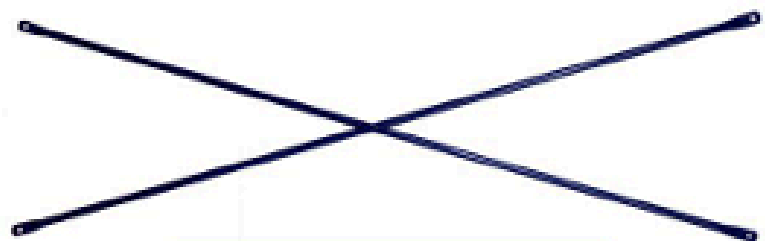

CROSS BRACE



JOINT PIN

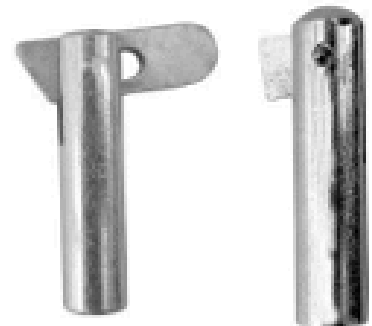

LOCK PIN

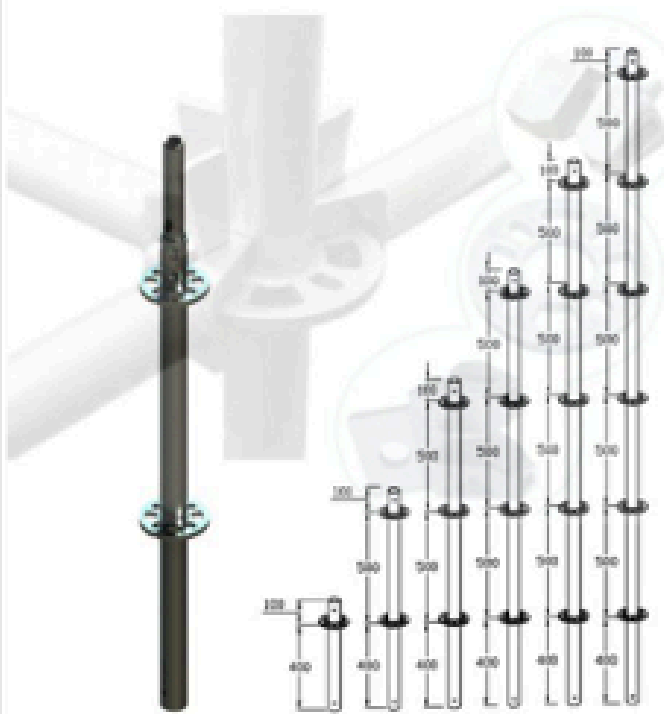

RINGLOCK STANDARD

S.NO	PRODUCT	WEIGHT/PC
1	LOCK STANDARD .5 MTR WITH JOINT PIN	3.2 KG
2	LOCK STANDARD 1 MTR WITH JOINT PIN	5.70 KG
3	LOCK STANDARD 1.5 MTR WITH JOINT PIN	8.0 KG
4	LOCK STANDARD 2 MTR WITH JOINT PIN	10.40 KG
5	LOCK STANDARD 2.5 MTR WITH JOINT PIN	12.80 KG
6	LOCK STANDARD 3 MTR WITH JOINT PIN	15.0 KG
7	LOCK STANDARD 4 MTR WITH JOINT PIN	20.20 KG

S.NO	PRODUCT	WEIGHT/PC
1	LOCK LEDGER WITH CASTED END .4 MTR	2.32 KG
2	LOCK LEDGER WITH CASTED END .73 MTR	3.38 KG
3	LOCK LEDGER WITH CASTED END 1.09 MTR	4.74 KG
4	LOCK LEDGER WITH CASTED END 1.40 MTR	6.57 KG
5	LOCK LEDGER WITH CASTED END 1.57 MTR	6.57 KG
6	LOCK LEDGER WITH CASTED END 2.07 MTR	8.46 KG
7	LOCK LEDGER WITH CASTED END 2.57 MTR	10.36 KG
8	LOCK LEDGER WITH CASTED END 3.07 MTR	12.22 KG

S.NO	PRODUCT	WEIGHT/PC
1	LOCK DIAGNAL BRACE 3.2 MM WITH CASTED END 0.5 MTR	2.45 KG
2	LOCK DIAGNAL BRACE 3.2 MM WITH CASTED END 1.0 MTR	4.90 KG
3	LOCK DIAGNAL BRACE 3.2 MM WITH CASTED END 1.5 MTR	7.30 KG
4	LOCK DIAGNAL BRACE 3.2 MM WITH CASTED END 2.0 MTR	10.14 KG
5	LOCK DIAGNAL BRACE 3.2 MM WITH CASTED END 2.5 MTR	12.65 KG
6	LOCK DIAGNAL BRACE 3.2 MM WITH CASTED END 3.0 MTR	15.20 KG



RING LOCK LEDGER



CROSS BAR

10 STAGES



CONTACT US

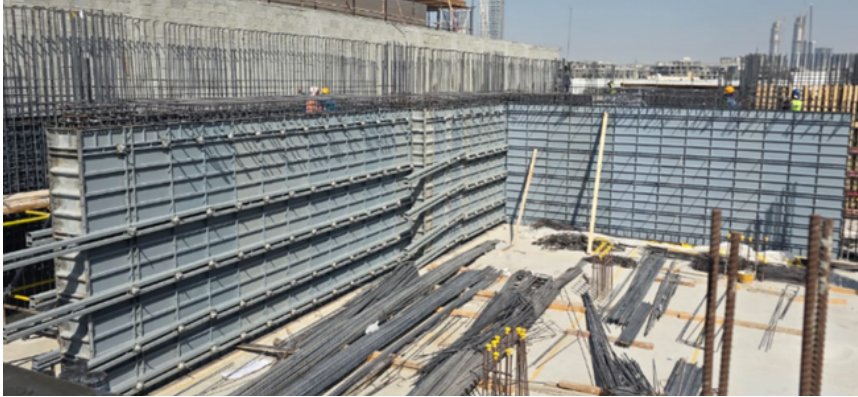

LOCATION: Youssef Zahra Building. Al Quoz, Dubai - UAE
PHONE NUMBER: +971508652585
EMAIL ID: sales@gfsformwork.com